

***Series 2000 Reader System***  
***High Performance Reader Frequency Module***  
***RI-RFM-007B***

***Reference Guide***

***November 2002***

---



**SCBU022**

# ***Series 2000 Reader System***

***High Performance Reader Frequency Module  
RI-RFM-007B***

## ***Reference Guide***



Literature Number: SCBU022

November 2002



<b>Preface</b> .....	<b>5</b>
<b>1 Product Description</b> .....	<b>7</b>
1.1 General.....	8
1.2 Transmitter.....	9
1.3 Receiver .....	10
1.4 RFM Connectors and Jumpers .....	10
<b>2 Specifications</b> .....	<b>15</b>
2.1 Recommended Operating Conditions .....	16
2.2 Dimensions.....	19
<b>3 Installation</b> .....	<b>21</b>
3.1 Power Supply Requirements .....	22
3.2 Power Supply Connection.....	22
<b>4 Associated Antenna Systems</b> .....	<b>25</b>
4.1 Antenna Requirements .....	26
4.2 Antenna Resonance Tuning .....	27
4.3 Tuning Procedure .....	27
<b>5 Regulatory, Safety &amp; Warranty Notices</b> .....	<b>31</b>
5.1 Regulatory Notes .....	32
5.1.1 FCC Notices (U.S.A).....	32
5.1.2 CE Conformity (Europe).....	32
<b>A Expanding Antenna Tuning Inductance Range</b> .....	<b>33</b>
<b>B Field Strength Adjustment</b> .....	<b>37</b>
<b>C Adjustment of Oscillator Signal Pulse Width</b> .....	<b>39</b>
<b>D Threshold Level Adjustment</b> .....	<b>41</b>
<b>E Transmitter Carrier Phase Synchronization (CPS)</b> .....	<b>43</b>
<b>F Noise Considerations</b> .....	<b>45</b>
<b>G Over Voltage Protection</b> .....	<b>47</b>

---

## List of Figures

1-1	RFM Block Schematic.....	8
1-2	Pulse Width Examples .....	9
1-3	RFM Top View.....	11
1-4	RFM Bottom View .....	12
2-1	Mechanical Dimensions .....	19
3-1	External Ground Connection (GND to GNDP) .....	23
4-1	Tuning Example Showing Increase of Total Tuning Capacity and Generated Field Strength (Typical Values).....	28
4-2	Flow Chart for Tuning the Antenna to Resonance.....	29
A-1	Circuit for Expanding Antenna Tuning Range to Lower Values.....	33
A-2	Circuit for Expanding Antenna Tuning Range to Higher Values .....	34
E-1	Distance Between Antennas (Top View).....	43
F-1	Noise Testing Configuration .....	46
G-1	Circuit for Overvoltage Protection .....	48

## List of Tables

1-1	J1 Pin Functions.....	12
1-2	J2 Pin Functions.....	13
1-3	J4 Pin Functions.....	13
1-4	J3 Pin Functions.....	13
1-5	Antenna Connectors .....	14
1-6	Transmitter Carrier Phase Synchronization (CPS) Dip Switch SW1 .....	14
2-1	Operating Conditions .....	16
2-2	Electrical Characteristics .....	17
2-3	Timing Characteristics .....	18
2-4	Mechanical Parameters .....	18
3-1	Power Supply Ripple Specifications .....	22
4-1	Antenna Requirements .....	26
A-1	Capacitor Values for Expanding Antenna Tuning Range to Lower Values.....	34
A-2	Capacitor Values Expanding Antenna Tuning Range to Higher Values .....	35
C-1	Oscillator Signal Pulse Width vs Resistor Value (Estimated Values) .....	39
E-1	Maximum Distances Between Antennas .....	43
F-1	Characteristics of Radiated and Conducted Noise .....	45

### **Fifth Edition – November 2002**

This manual describes the TI-RFid™ High Performance Reader Frequency Module RI-RFM-007B, hereafter referred to as the RFM.

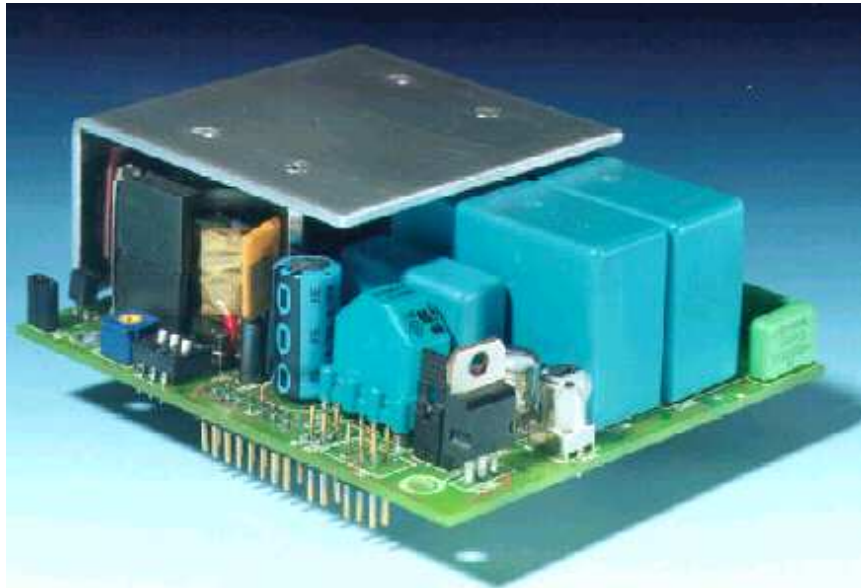

### **Conventions**

Certain conventions are used in order to display important information in this manual, these conventions are:

#### **WARNING**

**A WARNING IS USED WHERE CARE MUST BE TAKEN, OR A CERTAIN PROCEDURE MUST BE FOLLOWED, IN ORDER TO PREVENT INJURY OR HARM TO YOUR HEALTH.**

#### **CAUTION**

This indicates information on conditions which must be met, or a procedure which must be followed, which if not heeded could cause permanent damage to the RFM.

**Note:** Indicates conditions which must be met, or procedures which must be followed, to ensure proper functioning of the RFM.

---

## **Trademarks**

The TI-RFid logo and the words TI-RFid and Tag-it are trademarks or registered trademarks of Texas Instruments.

## ***Product Description***

---

---

---

This chapter introduces the RFM component assemblies, showing the transmitter and receiver sections and placement of key user-accessible components.

<b>Topic</b>	<b>Page</b>
<b>1.1 General</b> .....	<b>8</b>
<b>1.2 Transmitter</b> .....	<b>9</b>
<b>1.3 Receiver</b> .....	<b>10</b>
<b>1.4 RFM Connectors and Jumpers</b> .....	<b>10</b>

1.1 General

**WARNING**

**CARE MUST BE TAKEN WHEN HANDLING THE RFM. HIGH VOLTAGE ACROSS THE ANTENNA TERMINALS, ALL ANTENNA COMPONENTS AND SOME PARTS OF THE PRINTED CIRCUIT BOARD (PCB) COULD BE HARMFUL TO YOUR HEALTH. IF THE ANTENNA INSULATION IS DAMAGED, THE ANTENNA SHOULD NOT BE CONNECTED TO THE RFM.**

**CAUTION**

This product may be subject to damage by electrostatic discharge (ESD). It should be handled by ESD protected personnel at ESD secured workplaces only. The transmitter power output stage can only operate with a limited duty cycle. Please pay attention to this whilst performing antenna tuning procedures. Ground pins GND and GNDP must be connected externally to avoid damage to the unit.

The RFM is an integral part of the TI-RFid system. Coupled with a Control Module and an antenna, it is used for wireless identification of TI-RFid transponders. A block schematic is shown in [Figure 1-1](#).

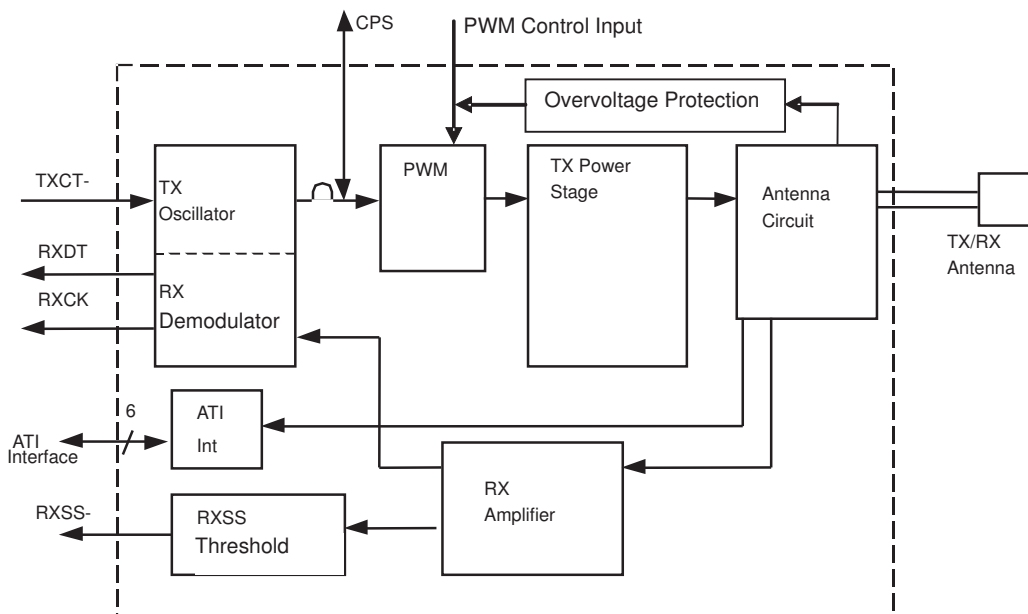

**Figure 1-1. RFM Block Schematic**

The RFM contains all the analogue functions of a TI-RFid reading unit needed to send an energizing signal via the antenna to initialize a TI-RFid transponder, to demodulate the received identification signal and to send the received data together with clock signals to a Control Module.

The RFM also sends the necessary programming and addressing signals to Read/Write and Multipage transponders.



The data input and output lines, which are connected to a data processing unit, are low-power Schottky TTL and HCMOS logic compatible.

The functions of the RFM are described in [Section 1.2](#).

## 1.2 Transmitter

The transmitter power stage is supplied with power via two separate supply lines VSP and GNDP. Because of the high current requirements for the transmitter power stage, these supply lines are separated from the logic section supply lines and have two pins per line.

The ground pins for the logic section and the transmitter are not connected internally in order to avoid possible problems with a high resistivity of GNDP pins and in order to increase flexibility when using long supply lines. Pins GND and GNDP must be connected to each other externally. For more details, refer to [Section 3.1](#), Power Supply Connection.

The regulated transmitter power stage supply may vary between +7 V and +24 V. The supply lines VSP and VSL should be connected together when the supply voltage is +7 V or more. For details refer to [Chapter 2](#), Specifications.

---

**Note:** The RFM has an in-built temperature protection circuit which sharply limits the transmitter power stage output if an over-current situation or an over-temperature environment causes the temperature to exceed the allowed limits. After the device is switched off and has time to recover (when the temperature drops again or the over-current situation is otherwise rectified) the unit reverts to normal operation when it is switched on again. Such an occurrence is an indication that the RFM is not being operated within specification.

---

The transmit frequency (134.2 kHz) from the oscillator is fed to the pulse width modulator (PWM). By changing the value of a resistor, the PWM can set the pulse width ratio between 0% and 50%. For an example of two different oscillator signal pulse widths see [Figure 1-2](#). Decreasing the 134.2 kHz frequency pulse width ratio decreases the generated transmit (charge-up) field strength.

It is therefore possible to adjust the generated field strength by selecting different pulse width ratios. For more information about setting the field strength, refer to [Appendix B](#), Field Strength Adjustment.

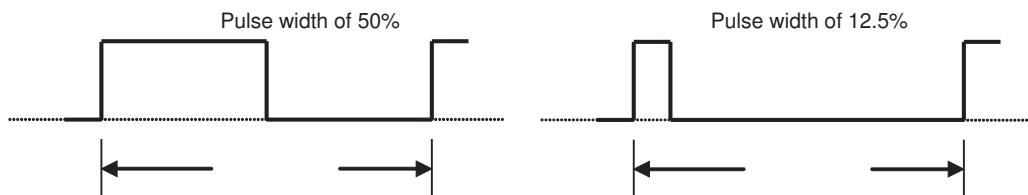

**Figure 1-2. Pulse Width Examples**

### CAUTION

The RFM must not be operated in continuous transmit mode when operated at full power output. For details please refer to [Chapter 2](#), Specifications. When using pulse widths smaller than 50%, the RFM transmitter power stage works in a less efficient way. This leads to an increased power dissipation and thus to higher temperature increase of the transmitter power stage, so ensure that more cooling is provided.

---

**Note:** If the RFM is going to be physically located within the antenna field, it may be necessary to shield the module.

---

### 1.3 Receiver

The signal received from the transponder is a frequency shift keying (FSK) signal with typical low and high bit frequencies of 134.2 kHz and 123.2 kHz respectively. The signal is received from the antenna resonator, which is capacitively coupled to the receiver.

The signal RXCK is the reference clock signal to decode the RXDT data stream. The RXCK signal changes from low to high level during each data bit and the RXDT signal is valid before and after this positive slope for a certain time window. For more details refer to [Table 2-3, Timing Characteristics](#).

The receiver also has a built-in RF receive signal strength detector. The receive signal strength is indicated by the digital output RXSS-.

RXSS- becomes active (logic low level) when the received RF signal strength exceeds a defined level. This threshold level can be adjusted with a potentiometer (R409) on the RFM. The potentiometer is located near SW1 on the board. See [Figure 1-3, RFM Top View](#).

The RXSS- output is used for detection of other transmitting reading units and thus can be used for wireless read cycle synchronization of several reading units.

### 1.4 RFM Connectors and Jumpers

There are a number of connectors, jumpers and other components on the RFM available for use.

These are:

J1	Connector for supply voltages and interface signal lines to and from the RFM
J2	Connector for the (optional) Antenna Tuning Indicator (ATI), which can be used for easy antenna tuning during installation.
J3	Connector for antenna resonance tuning, used to connect the required tuning capacitors.
J4	Connector for field strength adjustment resistor and also direct access to receiver input.
J5	Additional antenna damping Jumper.
J6	Common-mode noise choke bypass.
R409	RXSS noise level adjustment potentiometer.
SW1	Default all on. (SW1/1 CPS setting see <a href="#">Appendix E</a> .)
ANT1/ANT2	(Two M3 screw connectors) Connect the transmit/receive (TX/RX) antenna to the RFM.

The RFM is normally mounted from the underside utilizing appropriate spacers and M3 mounting bolts.

The top view of the RFM (without the normally fitted heatsink) is shown in [Figure 1-3](#). Connectors J2, J3, J4, J5, J6, R409, switch SW1 and the antenna terminals are accessible from the top.

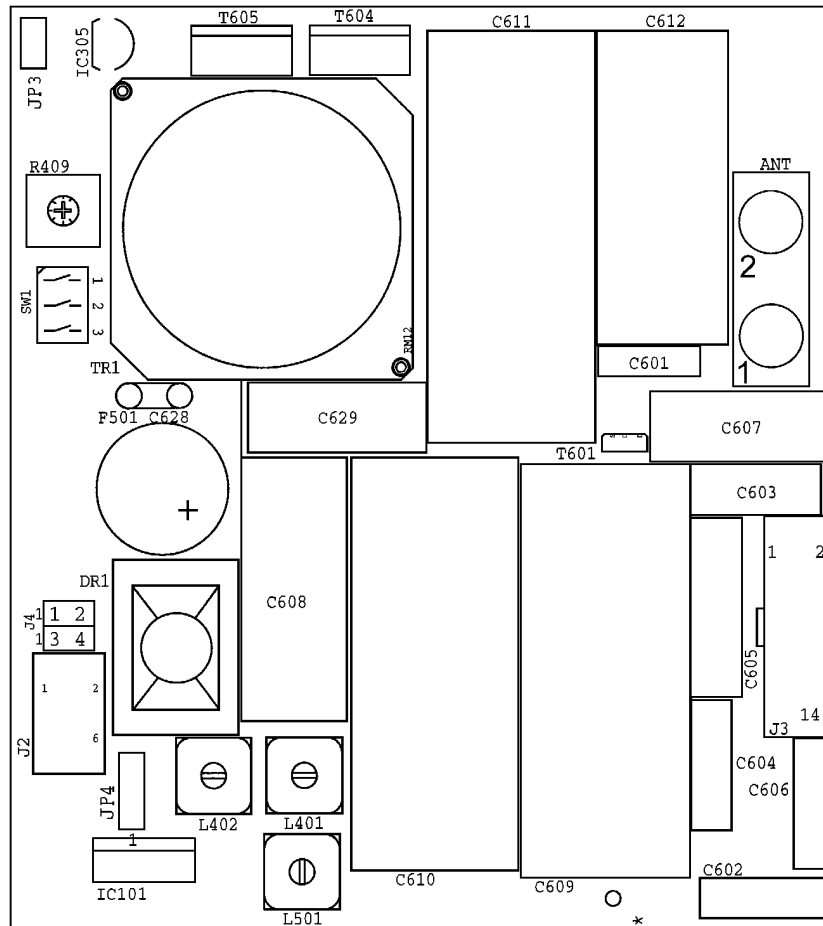

**Figure 1-3. RFM Top View**

The bottom view of the RFM is shown in [Figure 1-4](#). The connectors J1, J2, J3 and J4 are accessible from the underside. J1 is the 16-pin module connector, this carries the supply voltage lines, the data, and the control lines.

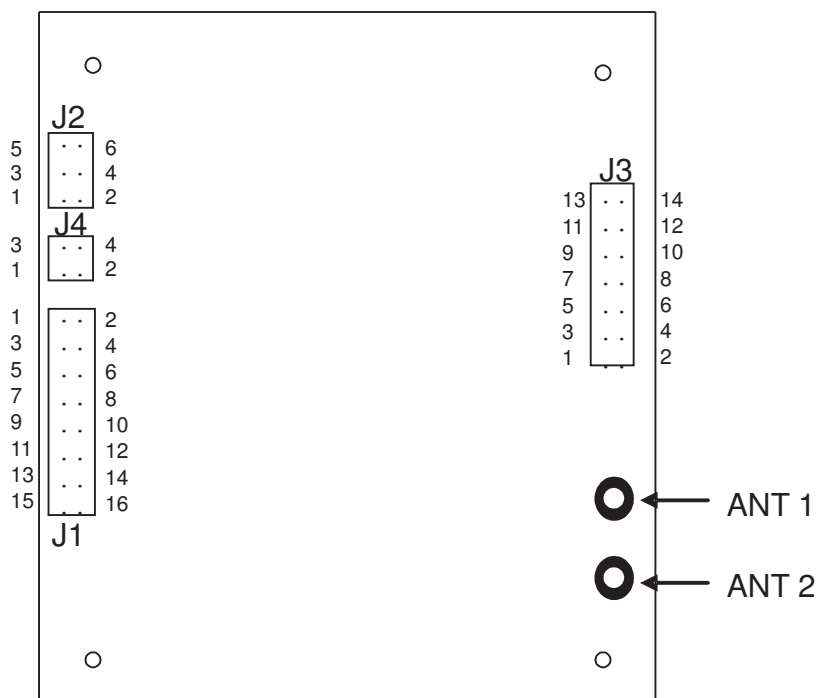

**Figure 1-4. RFM Bottom View**

[Table 1-1](#) lists the pin functions for connector J1. The connector type is 16 pin, 2 row with 2.54 mm pin spacing.

**Table 1-1. J1 Pin Functions**

Pin#	Signal	Direction	Description
1	GND	IN	Logic ground
2	TXCT-	IN	Transmitter control input for activation of transmitter (active low, internal pull-up resistor)
3	VSL	IN	Supply voltage for logic and receiver
4	RXDT	OUT	Logic level compatible receiver data signal output
5	RXSA	IN/OUT	Receiver signal strength adjust for RXSS- threshold level
6	RXCK	OUT	Logic level compatible receiver clock output
7	GNDP	IN	Transmitter power stage ground
8			No connection
9	GNDP	IN	Transmitter power stage ground
10	RSTP	OUT	Analog receiver signal strength test pin
11	VSP	IN	Supply voltage for transmitter power stage
12	CPS_OUT	OUT	Carrier Phase Synchronization oscillator signal output
13	VSP	IN	Supply voltage for transmitter power stage
14	RXSS-	OUT	Receiver signal strength output (active low)
15			No connection
16	CPS_IN	IN	Carrier Phase Synchronization oscillator signal input

### CAUTION

The transmitter ground pins GNDP and logic ground pin GND must be connected together externally. The RFM may be otherwise permanently damaged.

[Table 1-2](#) lists the pin functions for the ATI connector J2: The connector type is a 6 pin, 2 row connector with 2.54 mm pin spacing.

**Table 1-2. J2 Pin Functions**

Pin #	Signal	Direction	Description
1	TXCT-R	IN	Transmitter control signal via resistor (active low)
2	GND	OUT	Logic ground
3	VD	OUT	Internal regulated logic supply voltage output
4	F_OSC-R	IN/OUT	Pulse width modulated transmitter oscillator signal via resistor
5	RXSS-	OUT	Receiver signal strength output (active low)
6	F_ANT	OUT	Antenna resonance frequency output signal (open collector)

[Table 1-3](#) lists the pin functions for the J4 pulse width adjustment connector. The connector type is 4 pin, 2 row with 2.54 mm pin spacing.

**Table 1-3. J4 Pin Functions**

Pin#	Signal	Description
1	RX	Analog transponder signal
2	GNDA	Ground antenna circuit
3		Pulse width adjusting resistor connecting pin
4	GND	Logic ground

[Table 1-4](#) lists the functions for connector J3. This is a 14 pin, 2 row connector with 2.54 mm pin spacing.

**Table 1-4. J3 Pin Functions**

Pin#	Signal	Description
1	ATC1	Antenna tuning capacitor 1 (weighted value 1)
2	GNDA	Ground antenna circuit
3	ATC2	Antenna tuning capacitor 2 (weighted value 2)
4	GNDA	Ground antenna circuit
5	ATC3	Antenna tuning capacitor 3 (weighted value 4)
6	GNDA	Ground antenna circuit
7	ATC4	Antenna tuning capacitor 4 (weighted value 8)
8	GNDA	Ground antenna circuit
9	ATC5	Antenna tuning capacitor 5 (weighted value 16)
10	GNDA	Ground antenna circuit
11	ATC6	Antenna tuning capacitor 6 (weighted value 32)
12	GNDA	Ground antenna circuit
13	AMTP	Antenna circuit test point
14		No connection

Table 1-5 lists the pin functions for the antenna terminal connectors: Metric screws size M3 are used for connection.

**Table 1-5. Antenna Connectors**

Signal	Description
ANT1	Antenna resonator (capacitor side)
ANT2	Antenna resonator (transformer side)

Jumper JP6 allows enabling and disabling of common noise filtering for EMI purposes. The default setting, with common noise filtering active, jumpers pins 2 and 3. A jumper between pins 1 and 2 bypasses common noise filtering.

**Table 1-6. Transmitter Carrier Phase Synchronization (CPS) Dip Switch SW1**

Dip-Switch	Position	Description
1	ON	On = RFM Master (default) Off = RFM Slave
2	ON	Must be in ON Position
3	ON	Must be in ON Position

# Specifications

---

---

---

This chapter lists the recommended operating conditions, electrical and mechanical characteristics and dimensions.

Topic	Page
2.1 Recommended Operating Conditions .....	16
2.2 Dimensions .....	19

## 2.1 Recommended Operating Conditions

**CAUTION**

Exceeding recommended maximum ratings may lead to permanent damage of the RFM. The RFM must not be operated in continuous transmit mode when operated at full power output. Install suitable heatsinks when operating the RFM at pulse widths smaller than 50%.

Table 2-1 shows the recommended operating conditions.

**Table 2-1. Operating Conditions**

Symbol	Parameter	Min	Typ	Max	Unit
V_VSP	Supply voltage of transmitter power stage	7.0	12.0	24.0	V DC
I_VSP	Current consumption of transmitter power stage - refer to the formula below		1.0	1.7	Apeak
P_VSP	Peak pulse power input to transmitter power stage (I_VSP * V_VSP * Duty Cycle)			20	W
V_ANT	Antenna resonance voltage		250	380	Vpeak
V_ANT-25	Antenna resonance voltage (Pulse width setting ≤ 25%)			200	Vpeak
V_ANT-D1	Antenna resonance voltage for damping option using jumper JP3		50	60	Vpeak
V_ANT-ATI	Minimum antenna resonance voltage for correct operation of ATI	25			Vpeak
V_VSL	Supply voltage input for logic part	7.0		24.0	V DC
I_VD	External current load on internal regulated logic supply voltage output			1.0	mA
T_oper	Operating free-air temperature range	-25		+70	°C
T_store	Storage temperature range	-40		+85	°C

**Note:** Free-air temperature is the air temperature immediately surrounding the RFM module. If the module is incorporated into a housing, it must be guaranteed by proper design or cooling that the internal temperature does not exceed the recommended operating conditions.

In order to keep power consumption (P\_VSP) below 20 W it is advisable to limit I\_VSP. The maximum allowed value, dependent on the configuration, can be determined as follows (in the following examples a supply voltage of 24 V\_VSP is used):

$$I_{VSP} = \frac{P_{VSP}}{V_{VSP} \times \text{Duty Cycle}}$$

where Duty Cycle =  $\frac{\text{Power on time}}{\text{Total Read Cycle Time}}$

**Example 1:** Using Standard/Default Settings (≈10 read cycles/second)

$$I_{VSP} = \frac{20 \text{ W}}{24 \text{ V} \times 0.5} = 1.66 \text{ A} \quad \text{Duty Cycle} = \frac{50 \text{ ms}}{100 \text{ ms}} = 0.5$$

**Example 2:** Configured to No Sync (≈12 read cycles/second)

$$I_{VSP} = \frac{20 \text{ W}}{24 \text{ V} \times 0.625} = 1.33 \text{ A} \quad \text{Duty Cycle} = \frac{50 \text{ ms}}{80 \text{ ms}} = 0.625$$



The following methods can be used to measure the actual I\_VSP value:

1. Use a battery powered oscilloscope to measure the voltage drop across a 0.1  $\Omega$  resistor placed in the DCIN+ line, and then calculate the actual current using the formula  $I = V/R$ .
2. If a battery powered oscilloscope is not available, measure the potential at both sides of the 0.1  $\Omega$  resistor (signal probe) with the GND probe at DCIN- and determine the potential difference. Ensure that the measured I\_VSP value does not exceed the calculated value.

**Table 2-2. Electrical Characteristics**

Symbol	Parameter	Min	Typ	Max	Unit
I_VSL	Supply current for logic and receiver part in transmit and receive mode	14	18	22	mA
ViL	Low level input voltage of TXCT-	0	0.4	0.8	V
ViH	High level input voltage of TXCT-	2.4		5.0	V
VoL	Low level output voltage of RXDT and RXCK	0	0.4	0.8	V
VoH	High level output voltage of RXDT and RXCK	4.0		5.25	V
VoL_R	Low level output voltage of RXSS-			0.8	V
VoH_R	High level output voltage of RXSS- (see note below)			5.25	V
Fan-In	Low power Schottky compatible fan-in of signals TXCT- (I <sub>in</sub> = -400 $\mu$ A)			1	-
I_IN-TXCT-	Input current for TXCT- signal, when the Accessory Module RI-ACC-AT12 is connected	2.0	2.5	3.0	mA
Fan-Out	Low power Schottky compatible fan-out of signals RXDT and RXCK			3	-
FanOut_RI	Low power Schottky compatible fan-out of signal RXSS- (low level only)			1	-
FanOut_Rh	Low power Schottky compatible fan-out of signal RXSS- (high level only) (see note below)				
I_J1	Cable length for connecting J1 of RFM to a Control Module using flat cable	0	0.5	2.0	m
I_CPS	Cable length for connecting the Carrier Phase Synchronization signal between two RFMs	0	1.0	5.0	m
n_CPS	Number of oscillator SLAVE RFMs, which can be driven from one oscillator MASTER RFM	1		5	-
Com_Mode	Common Mode Noise reduction ratio for noise coupled to both antenna terminals ANT1 and ANT2		20		dB
R_GND	Decoupling resistor between GND and GNPD ( $\pm 5\%$ )	64.6	68	71.4	$\Omega$

---

**Note:** RXSS- has an internal pull-up resistor of 10 k $\Omega$ . The parameter VoH\_R therefore depends on application specific external components.

---

**Table 2-3. Timing Characteristics**

Symbol	Parameter	Min	Typ	Max	Unit
t_TX	Transmit burst length for correct operation (see note below)	15	50	100	ms
t_dtck	Delay time from beginning of data bit at RXDT being valid to positive slope of RXCK signal	20			μs
t_dtvd	Time for data bit of RXDT signal being valid after positive slope of RXCK	90			μs
t_ckhi	Time for clock signal RXCK being high	55			μs
t_ri t_fi	Necessary rise and fall times for input signal TXCT- and TXCT-R			1	μs
t_ro t_fo	Rise and fall time of output signals RXDT and RXCK			1	μs
t_ro_R	Rise time of output signal RXSS- (no external connection)			1	μs
t_fo	Fall time of output signal RXSS-			1	μs
tss_01TI	Propagation delay time from positive slope of TXCT- to positive slope of RXSS- signal (maximum sensitivity)	500	1000	1500	μs
tss_10Tr	Propagation delay time from negative slope of TXCT- to negative slope of RXSS- signal (minimum sensitivity)	50	100	200	μs
t_short	Maximum time of short circuit between antenna terminals ANT1 and ANT2 and short circuit of ANT1 or ANT2 to GNDA			10	s

**Note:** Due to transponder parameters a minimum charge-up time of 15 ms is necessary. Decreasing charge-up time decreases read range by sending less energy to the transponder.

**CAUTION**

The parameter t\_short refers to a static short circuit of the antenna terminals. Shorting the antenna terminals during operation may cause permanent damage to the RFM.

**Table 2-4. Mechanical Parameters**

Parameter	Typical	Unit
Height including mounting bolts	44.0 ± 1.5	mm
Weight approx.	251	g

**Note:** The heatsink is connected to the antenna resonator ground GNDA. When connecting the heatsink to a housing, the heatsink must be insulated from the housing.

## 2.2 Dimensions

All measurements are in millimeters with a tolerance of  $\pm 0.5$  mm unless otherwise noted.

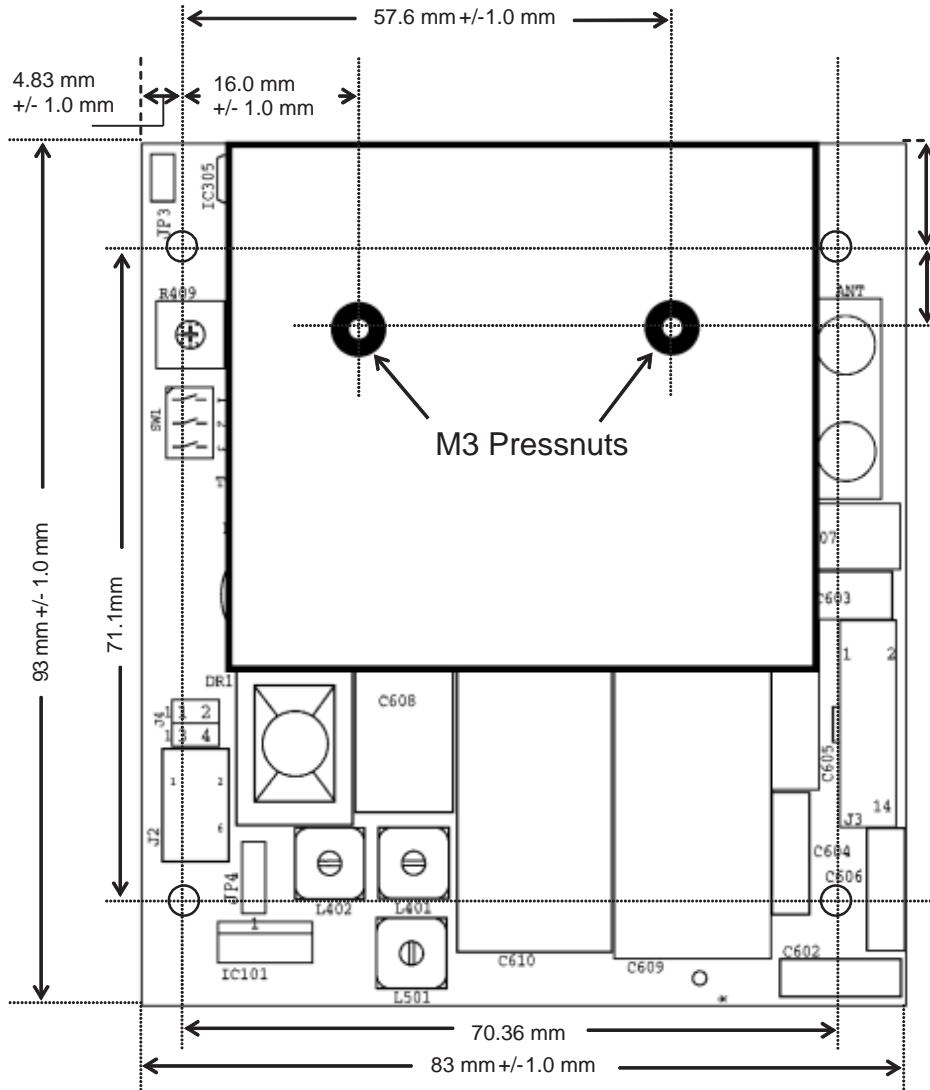

**Figure 2-1. Mechanical Dimensions**



## **Installation**

---

---

---

This chapter shows how to install the RFM and specifies power supply requirements and connections.

Topic	Page
3.1 Power Supply Requirements .....	22
3.2 Power Supply Connection .....	22

### 3.1 Power Supply Requirements

The logic and receiver sections of the RFM must be supplied via the VSL and GND pins with unregulated voltage.

The transmitter power stage is separately supplied via VSP and GNDP. As there is no stabilization circuitry on the RFM and as the transmitter power stage needs a regulated supply voltage in order to meet FCC/R&TTE regulations, the supply voltage for the transmitter power stage must be regulated externally. For the voltage supply range please refer to [Chapter 2](#), Specifications.

---

**Note:** The RFM should not be supplied by switched mode power supplies (SMPS) as most SMPS operate at frequencies of around 50 kHz. The harmonics of the generated field may interfere with the TI-RFid receiver and therefore only linear power supplies, or SMPS with a fundamental operating frequency of 200 kHz or higher are recommended.

---

Noise from power supplies or from interface lines may interfere with receiver operation. It is recommended to add additional filters in series to the supply and interface lines if required by the application. For more details refer to [Appendix F](#), Noise Considerations and [Appendix G](#), Over Voltage Protection.

In order to guarantee full RFM performance, the power supplies should fulfill the specifications for ripple voltage given in [Table 3-1](#).

**Table 3-1. Power Supply Ripple Specifications**

Supply Type	Maximum Ripple Voltage	Allowable Ripple Frequency
Unregulated VSL supply	30 mVrms	0 to 100 kHz maximum (sinusoidal)
Regulated VSP supply	50 mVrms	0 to 50 kHz maximum (sinusoidal)

### 3.2 Power Supply Connection

Ground pins for the logic/receiver part and the transmitter power stage are not directly connected internally, the two different grounds having to be connected to each other externally.

The only internal connection is via resistor R\_GND, in order to avoid floating grounds if these grounds are accidentally not connected to each other externally.

This is necessary for two reasons:

1. A high resistivity of the GNDP pins could cause a voltage drop across these pins, due to high transmitter power stage current (this does not apply to the supply pins of the logic section). If the grounds were connected to each other internally, this would also lift the internal logic ground and cause logic level compatibility problems with the Control Module (see [Figure 3-1](#)).
2. In order to provide greater flexibility when using long supply lines. Long VSP supply lines between the RFM and the Control Module cause a voltage drop across this supply line (again due to high transmitter power stage supply current). This voltage drop would also lift the logic ground and cause logic level compatibility problems with the Control Module. This can be avoided by connecting the grounds externally in any of three different ways (see also [Figure 3-1](#)) as described below:
  - For cable lengths of up to 0.5 m between RFM and Control Module, the RFM ground pins GND and GNDP must be connected at the Control Module, as shown in [Figure 3-1](#). The grounds for the VSP, VSL and the Control Module supply are connected together at a common ground. Alternatively, if the voltage drop across the VSP supply line is less than 0.5 V (likely in this case), the ground pins GND and GNDP may be connected together at the RFM. If the system has a TI-RFid Control Module, the RFM ground pins GND and GNDP are already connected together correctly on the Control Module. When using a customer-specific controller, care must be taken to connect the RFM ground pins GND and GNDP to an appropriate ground on the controller.

- For cable lengths of between 0.5 m and 2 m, the RFM ground pins GND and GNDP must be connected together at the Control Module in order to avoid logic level compatibility problems caused by the voltage drop across the VSP supply lines. Connecting the ground pins at the RFM is not permitted since this would lift the logic ground level.
- Cable lengths longer than 2 m are not recommended. If the application demands cabling longer than 2 m, the logic signal connections between the RFM and the Control Module should be done via a differential interface (for example RS422). Due to different ground potentials at different locations it may also be necessary to provide galvanic separation of the interface signals by, for example, opto-couplers. In this case, to avoid problems with difference voltages between GND and GNDP, these pins must always be connected directly at the RFM. As shown in [Figure 3-1](#), a shorting bridge is necessary for this purpose, situated as close as possible to the RFM.

**CAUTION**

The voltage between GND and GNDP must not exceed  $\pm 0.5$  V, otherwise the RFM will suffer damage.

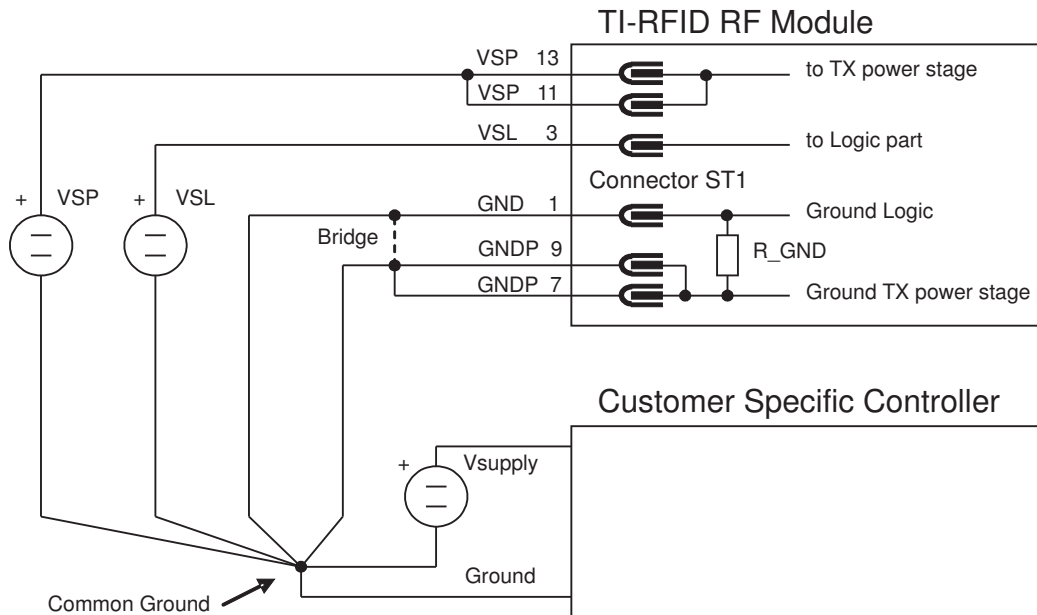

**Figure 3-1. External Ground Connection (GND to GNDP)**





## Associated Antenna Systems

---

---

---

This chapter discusses antenna requirements and antenna tuning procedures and flowcharts.

Topic	Page
4.1 Antenna Requirements .....	26
4.2 Antenna Resonance Tuning .....	27
4.3 Tuning Procedure .....	27

## 4.1 Antenna Requirements

In order to achieve high voltages at the antenna resonance circuit and thus high field strength at the antenna for the charge-up (transmit) function, the antenna coil must be high Q. The recommended Q factor for proper operation is listed in [Table 4-1](#), Antenna Requirements. The Q factor of the antenna may vary depending on the type, the construction and the size of the antenna. Furthermore, this factor depends on the wire type and wire cross-sectional area used for winding of the antenna.

RF braided wire, consisting of a number of small single insulated wires is recommended for winding of an antenna since it gives the highest Q factor and thus the highest charge-up field strength, for example single wire diameter of 0.1 mm (4 mil) and 120 single insulated wires.

**Note:** If a high Q is not required (for example for large in-ground antennas), standard braided wire can be used.

In order to ensure that the transmitter and receiver function correctly, the antenna must be tuned to the resonance frequency of 134.2 kHz. For a detailed description of the antenna resonance tuning procedure, refer to [Section 4.2](#), Antenna Resonance Tuning.

To ensure that the antenna can be tuned to resonance with the RFM, the antenna inductance can only vary within the limits given in [Table 4-1](#).

**Table 4-1. Antenna Requirements**

Parameter	Conditions	Min	Typ	Max	Unit
L_ANT	Antenna inductance range within which the antenna can be tuned to resonance	26	27	27.9	μH
Q_ANT	Recommended Q factor of antenna coil for correct operation	40		450	-

**Note:** Although a ferrite core antenna may have a high Q factor under test conditions with low magnetic field strengths, the Q factor decreases when a high magnetic field strength is applied to the ferrite core.

### **WARNING**

**CARE MUST BE TAKEN WHEN HANDLING THE RFM. HIGH VOLTAGE ACROSS THE ANTENNA TERMINALS AND ALL ANTENNA RESONATOR PARTS COULD BE HARMFUL TO YOUR HEALTH. IF THE ANTENNA INSULATION IS DAMAGED THE ANTENNA SHOULD NOT BE CONNECTED TO THE RFM.**

When low field strength for larger antennas is necessary ( $V_{peak} < 60$  V), the antenna resonator can additionally be damped by connecting an onboard damping resistor, which may be done by closing jumper JP3 (see [Figure 1-3](#)). This jumper is open by default.

### **CAUTION**

Only a certain maximum antenna resonance voltage is allowed for this option. Please refer to [Section 2.1](#), Recommended Operating Conditions, for details.

**Note:** The transformer of the transmitter power stage is operated at a high magnetic flux. Due to the high level of magnetic flux change, the transformer may emit an audible tone. This may also occur with antennas that have ferrite cores (e.g. TI-RFid Standard Stick Antenna RI-ANT-S02). This tone does not indicate a malfunction.

---

## 4.2 Antenna Resonance Tuning

In order to achieve a high charge-up field strength, the antenna resonator frequency must be tuned to the transmitter frequency of 134.2 kHz. This is done by changing the capacitance of the antenna resonator.

To compensate for the tolerances of the antenna coil and the capacitors, six binary weighted tuning capacitors (C\_ATC1 to C\_ATC6) have been included. Their values are weighted in steps of 1, 2, 4, 8, 16 and 32, where C\_ATC1 has the smallest value corresponding to the factor 1, C\_ATC2 has double the capacity of C\_ATC1, so that C\_ATC2 corresponds to the factor 2 and so on. Each of the 6 tuning pins has an adjacent ground pin for antenna tuning, using shorting bridges (jumpers).

Monitoring of the correct antenna resonance tuning can be performed using the Antenna Tuning Indicator (ATI) tool RI-ACC-ATI2.

This device allows the transmitter to be operated in pulsed mode, independently of the Control Module. It indicates by LEDs whether the tuning capacity should be increased or decreased (marked on the ATI as IN for increase and OUT for decrease) and when the antenna is tuned to resonance, in which case the green LED is on or flashing together with the IN or OUT LED. The device is plugged into the RFM connector J2 during the tuning procedure, power being supplied from this module.

The following notes refer to antenna resonance tuning in general:

---

**Note:** If an antenna has to be installed in an environment where metal is present, the tuning of the antenna must be done in this environment, since the presence of metal changes the inductance of the antenna. In addition, the Q factor of the antenna decreases, thereby decreasing the field strength. The extent of the inductance and quality factor reduction depends on the kind of metal, the distance of the antenna from it and its size.

When the oscillator signal pulse width, or the supply voltage VSP of a RFM with a pre-tuned ferrite core antenna (for example: RI-ANT-S02) is changed by a factor of more than 50%, the ferrite core antenna has to be re-tuned to the new conditions due to the inductance changing slightly at different field strengths.

Each antenna is tuned individually to the RFM and this results in a unique tuning jumper arrangement for this combination of antenna and RFM.

If a different antenna or RFM is connected, the new combination must be tuned to resonance again.

---

## 4.3 Tuning Procedure

1. Switch RFM power supply off.
2. Connect the antenna to the RFM by means of the two M3 screw connectors.
3. Install antenna tuning monitoring unit.
4. Switch RFM power supply on.
5. Tune antenna to resonance by changing the tuning capacity.
6. Switch RFM power supply off.
7. Disconnect monitoring unit.
8. Switch RFM power supply on again.

The antenna resonance tuning is now complete.

## Tuning Procedure

The tuning of a new antenna to the RFM is started with no jumpers (shorting bridges) connected. While monitoring the resonance condition as described above, the jumpers are plugged in or out, thus connecting and disconnecting the tuning capacitors in such a way that the total tuning capacity will increase in steps of the smallest capacitance  $C_{ATC1}$ .

Counting-up of the binary weighted tuning capacitors is in principle done in the following way:

1. No jumpers connected.
2. Connect  $C_{ATC1}$  (J3 pins 1 and 2).
3. Disconnect  $C_{ATC1}$  and connect  $C_{ATC2}$ .
4. Connect both  $C_{ATC1}$  and  $C_{ATC2}$  (and so on).

However, the tuning steps do not offer an absolutely continuously increasing function, due to component tolerances. It is therefore possible that when the tuning value is increased by one binary step the total tuning capacity actually decreases (especially from tuning step 31 to 32), which can result in the generated field strength not steadily increasing (as shown in [Figure 4-1](#)). This is not the case when using the Antenna Tuning Indicator tool (ATI) since the indicated resonance condition is always correct.

It is therefore recommended to perform resonance tuning according to the flow-chart shown in [Figure 4-2](#).

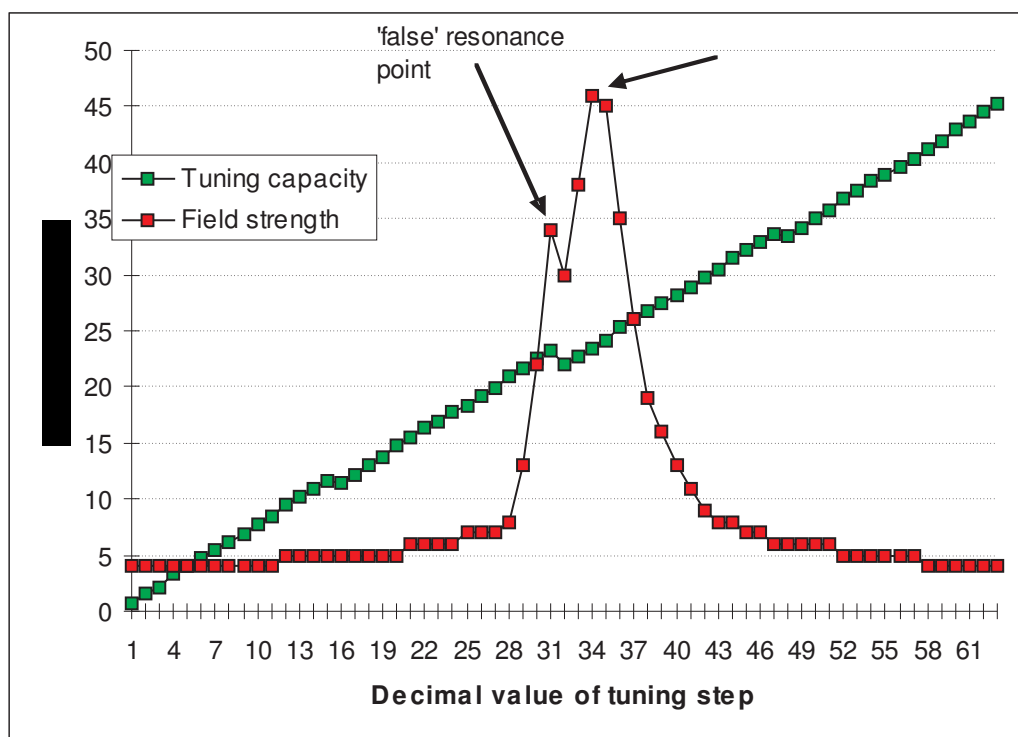

**Figure 4-1. Tuning Example Showing Increase of Total Tuning Capacity and Generated Field Strength (Typical Values)**

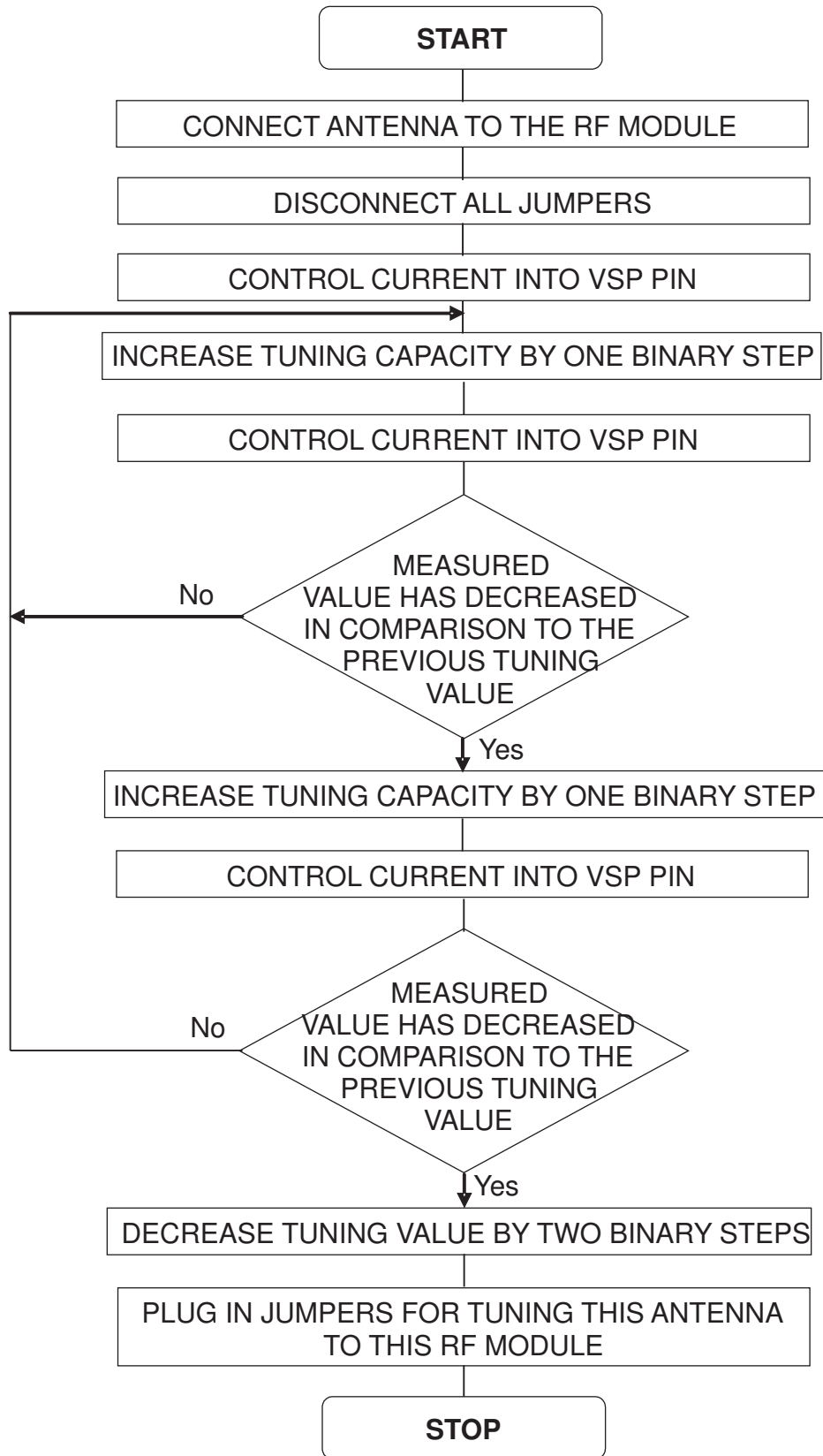

Figure 4-2. Flow Chart for Tuning the Antenna to Resonance



## ***Regulatory, Safety & Warranty Notices***

---

---

---

Topic	Page
5.1 Regulatory Notes .....	<b>32</b>

## 5.1 Regulatory Notes

Prior to operating the RFM together with antenna(s), power supply and a control module or other devices, the required FCC or relevant government agency (CE) approvals must be obtained. Sale, lease or operation in some countries may be subject to prior approval by government or other organizations.

### 5.1.1 FCC Notices (U.S.A)

A typical system configuration containing the RFM has been tested and found to comply with the limits for a Class A digital device, pursuant to part 15 of the FCC rules. It is the responsibility of the system integrators to get their complete system tested and to obtain approvals from the appropriate local authorities before operating or selling this system.

### 5.1.2 CE Conformity (Europe)

A CE Declaration of Conformity is available for the RFM at TI-RFid Sales Offices.

The equipment complies with the essential requirements of the Telecommunication Terminal Equipment Act (FTEG) and the R&TTE Directive 99/5/EC when used for its intended purpose.



Any device or system incorporating this module in any other than the originally tested configuration needs to be verified against the requirements of the Telecommunication Terminal Equipment Act (FTEG) and the R&TTE Directive 99/5/EC. A separate Declaration of Conformity must be issued by the system integrator or user of such a system prior to marketing it and operating it in the European Community.

It is the responsibility of the system integrators to get their complete system tested and obtain approvals from the appropriate local authorities before operating or selling the system.



## Expanding Antenna Tuning Inductance Range

It is possible to expand the tuning range of the antenna inductance. This may be necessary when TI-RFid standard antennas are used close to metal, when antenna extension cables are used or when customer specific antennas which might not be within the necessary antenna tuning inductance range are used.

**Note:** Please remember that the capacitors of external modules have to be able to withstand higher voltages when used together with a RFM.

Expanding the antenna tuning inductance range to lower or higher values can be done by connecting additional capacitors in parallel and in series to the antenna resonator.

The capacitors have to be connected in parallel and in series in order to withstand high voltages and currents occurring at the antenna resonance circuit.

### WARNING

**THERE IS HIGH VOLTAGE PRESENT AT ALL ANTENNA RESONATOR COMPONENTS, WHICH MAY BE HARMFUL TO HEALTH. THE RFM MUST BE SWITCHED OFF WHILE WORKING ON IT. EXTERNAL COMPONENTS MUST BE MOUNTED SUCH THAT THEY CANNOT BE ACCIDENTALLY TOUCHED.**

To ensure that the RFM functions correctly when the antenna tuning inductance range is expanded, special capacitors, as listed below, must be used:

Capacitor type:

- Polypropylene film capacitor
- Minimum 1250V DC operating voltage
- Capacitance tolerance: max.  $\pm 5\%$
- Type: SIEMENS "KP" or WIMA "FKP1"

The antenna tuning inductance range can be decreased to 13.7  $\mu\text{H}$  in six ranges, as shown in [Figure A-1](#) and [Table A-1](#).

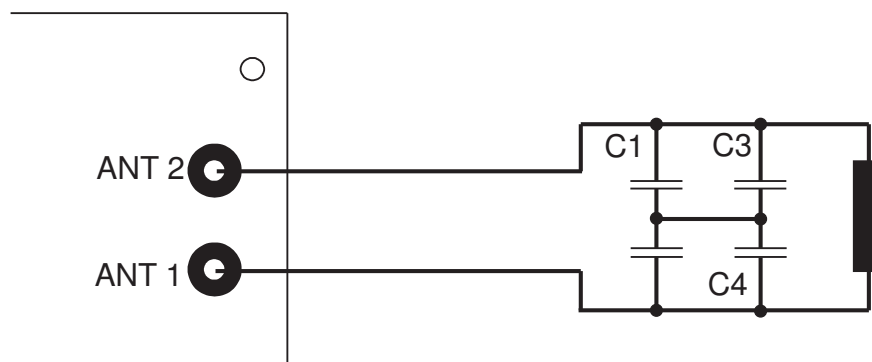

**Figure A-1. Circuit for Expanding Antenna Tuning Range to Lower Values**

**Table A-1. Capacitor Values for Expanding Antenna Tuning Range to Lower Values**

Antenna inductance range	Capacitor value
24.1 $\mu$ H to 25.9 $\mu$ H	C1, C2, C3, C4 = 3.3 nF
22.3 $\mu$ H to 24.0 $\mu$ H	C1, C2, C3, C4 = 6.8 nF
20.4 $\mu$ H to 22.2 $\mu$ H	C1, C2, C3, C4 = 11 nF (10 nF and 1 nF in parallel)
18.4 $\mu$ H to 20.3 $\mu$ H	C1, C2, C3, C4 = 16 nF
16.5 $\mu$ H to 18.3 $\mu$ H	C1, C2, C3, C4 = 22 nF
13.7 $\mu$ H to 16.4 $\mu$ H	C1, C2, C3, C4 = 32 nF

The antenna tuning inductance range can be increased to 37.6  $\mu$ H in 7 ranges, as shown in [Figure A-2](#) and [Table A-2](#).

As shown, three capacitors (C1, C2, C3) are connected in series with the antenna coil. The specification for these capacitors is listed below:

Capacitor type:

- Polypropylene film capacitor
- Minimum 1250 VDC operating voltage
- Capacitance: 47 nF  $\pm$ 2.5%
- Type: SIEMENS "KP" or WIMA "FKP1"

In addition to C1, C2 and C3, the capacitor C4 must be connected in parallel to the RFM antenna terminals. Different capacitor values are used for each range, the values being given in [Table A-2](#).

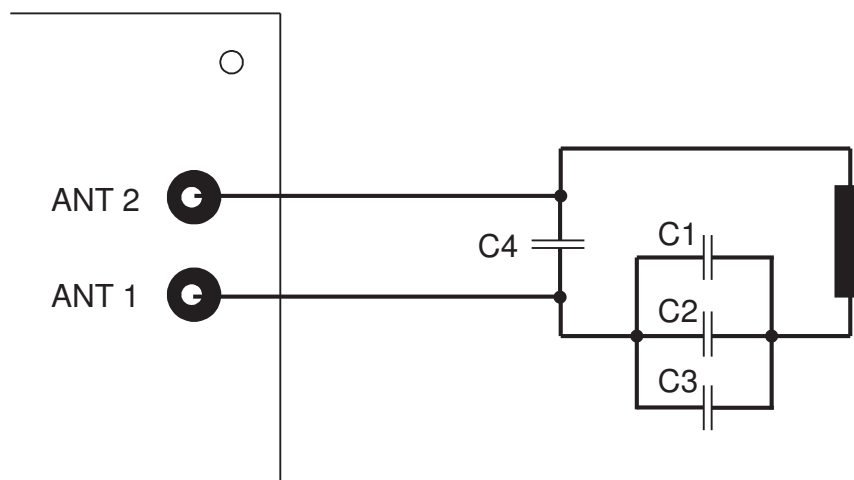

**Figure A-2. Circuit for Expanding Antenna Tuning Range to Higher Values**

**Table A-2. Capacitor Values Expanding Antenna Tuning Range to Higher Values**

Antenna inductance range	Capacitor Value <sup>(1)</sup>
28.0 $\mu$ H to 29.3 $\mu$ H	C4 = 18.3 nF (parallel 6.8 nF, 6.8 nF, 4.7 nF)
29.4 $\mu$ H to 31.0 $\mu$ H	C4 = 13.6 nF (parallel 6.8 nF, 6.8 nF)
31.1 $\mu$ H to 32.4 $\mu$ H	C4 = 10 nF
32.5 $\mu$ H to 33.8 $\mu$ H	C4 = 6.8 nF
33.9 $\mu$ H to 35.0 $\mu$ H	C4 = 3.98 nF (parallel 3.3 nF, 0.68 nF)
35.1 $\mu$ H to 36.2 $\mu$ H	C4 = 2.2 nF
36.3 $\mu$ H to 37.6 $\mu$ H	C4 not needed
Two serial connected TI-RFid standard antennas	C4 = 3.3 nF C2 and C3 not needed

<sup>(1)</sup> C1, C2, and C3 = 47 nF

**Note:** It is not recommended to use antennas with Q factors lower than 50. Antennas with inductances lower than 13.7  $\mu$ H or more than 37.8  $\mu$ H should not be used except when connecting two antennas in series since the additional capacitor values become very large. Antennas with fewer turns (i.e. smaller inductance) generate less charge-up field strength under the same operating conditions and in addition also have less receive sensitivity. Using capacitors parallel to the antenna resonator changes the coupling of the RFM's transmitter power stage thus reducing the generated field strength.

In order to avoid adaptation problems, it is strongly recommended to use standard TI-RFid antennas.



## Field Strength Adjustment

---

---

---

The magnetic field strength generated determines the charge-up distance of the transponder. The higher the magnetic field strength, the further the transponder charge-up distance. The charge-up distance does not, however, increase linearly with the field strength.

The reading distance of a transponder is determined, amongst other factors, by the charge-up distance and the local noise level. Increasing the charge-up field strength does not necessarily increase the reading distance.

The field strength generated by the RFM depends on the four factors listed below:

1. Q factor of the antenna.

The Q factor is a measure of the efficiency of the antenna and therefore the higher the Q factor of the antenna coil, the higher the field strength generated by the RFM, assuming that all other parameters remain unchanged. The Q factor of the antenna itself depends on the cross-sectional area of the wire, the wire type, the size of the antenna and the type of antenna (gate or ferrite). The larger the cross-sectional area of the RF braided wire, the higher the Q factor of the antenna. RF braided wire gives a higher Q factor than solid wire assuming that all other parameters remain unchanged.

2. Size of the antenna.

The larger the antenna, the higher the field strength which is generated by the RFM, since the antenna covers a larger area and thus generates a higher flux assuming that all other parameters remain unchanged. Large antennas have less immunity to noise for receive functions than small antennas.

3. Supply voltage of the RFM power stage.

The higher the supply voltage of the RFM transmitter power stage (VSP voltage), the higher the field strength which is generated by the RFM assuming that all other parameters remain unchanged. However, the generated field strength does not increase linearly with VSP supply voltage. In addition, ferrite core antennas show saturation effects (saturation means here that the ferrite core cannot generate more magnetic field strength, even with a higher input current).

4. The oscillator signal pulse width.

The bigger the selected transmitter oscillator signal pulse width, the higher the magnetic field strength which is generated by the RFM, since more power is fed into the antenna resonator by the transmitter power stage assuming that all other parameters remain unchanged.

The generated field strength can be measured in several ways. It may be measured using a calibrated field strength meter or by measuring the antenna resonance voltage using an oscilloscope and then calculating the field strength.

In summary: the generated field strength of an antenna can be adjusted with the supply voltage VSP of the RFM transmitter power stage and by selecting the corresponding oscillator signal pulse width.

In cases where low field strengths should be generated with large antennas (RI-ANT-G01 and RI-ANT-G04), the antenna resonator can be additionally damped by closing jumper JP3.

Using this optional damping function allows the field strength to be again fine-tuned to meet FCC/R&TTE regulations with selection of the oscillator signal pulse width in a wide range of both larger and smaller values.

**CAUTION**

This damping option can only be used together with the TI-RFid standard antennas RI-ANT-G01 and RI-ANT-G04. Only a certain maximum antenna resonance voltage is allowed for this option. Please refer to [Section 2.1](#), Recommended Operating Conditions, for details.

---

**Note:** For correct adjustment of field strength according to FCC/R&TTE values, especially for customized antennas, a calibrated field strength meter must be used. Field strength measurements must be taken on a free field test site according to VDE 0871 or equivalent regulation.

---

## Adjustment of Oscillator Signal Pulse Width

---



---

The RFM has an built-in feature to allow setting of the pulse width of the transmitter signal coming from the oscillator. This enables the generated field strength to be reduced from 50% down to 0%.

For this purpose a pulse width setting resistor may be inserted between J4 pins 3 and 4 on the RFM. Inserting a smaller resistance value decreases the pulse width and thus also the field strength. As default, no resistor is connected, thus selecting the maximum pulse width of 50% and the maximum field strength. By connecting a shorting bridge, the smallest pulse width of approximately 0% is selected.

**Table C-1** provides an overview of oscillator signal pulse width and corresponding field strength reduction when different oscillator signal pulse widths are selected by connecting different resistor values.

**Table C-1. Oscillator Signal Pulse Width vs Resistor Value (Estimated Values)**

Resistor value (k $\Omega$ )	Oscillator Signal Pulse Width (%)	Field Strength Reduction (dB)
open	50	0
151	37	-3
59	25	-6
17	12	-12
10	6	-18
shorted	0	$\infty$

### CAUTION

When using pulse widths smaller than 50%, the RFM transmitter power stage works less efficiently. This leads to an increased power dissipation and thus to a higher temperature of the transmitter power stage. Ensure that the antenna resonance voltage does not exceed 200 V<sub>p</sub> when the selected oscillator signal pulse width setting is smaller than 25%.

---

**Note:** The pulse width for an oscillator signal pulse width setting of 5% and smaller is extremely short. The pulse response of the RFM transmitter power stage to this short pulse is different for each unit. In order to have reproducible field strength values for different RFMs, it is not recommended to use the smallest pulse width setting.

---





## Threshold Level Adjustment

---

---

---

The RFM has a built-in receive signal field strength detector with the output signal RXSS- and an on-board potentiometer (R409) to adjust the threshold level of field strength detection. The digital output RXSS- is used for wireless synchronization of two or more reading units. This is necessary to ensure that if more than one reading unit is in an area, they do not interfere with each other. The Control Module software monitors the RXSS- signal to detect whether other reading units are transmitting. The Control Module can operate the transmitter of the RFM such that the reading units either transmit simultaneously or alternately. In this way the read cycles of each of the reading units occur at the same time or at secure different times. Depending on the antenna type used and the local noise level, the RXSS- threshold level has to be adjusted. This needs to be done after the antenna has been tuned to resonance. It is recommended to use a small screwdriver to adjust the RXSS- threshold level. The R409 potentiometer is located on the upper side of the RFM board near connector switch SW1. Turning the potentiometer all the way clockwise (right-hand stop), results in minimum threshold sensitivity, i.e. the RXSS- signal will be activated at high receive field strength. This is the default position and can be used for standard gate antennas. It may be necessary to increase the sensitivity when using ferrite core antennas. If there is high noise level in the area, it is necessary to adjust the RXSS- threshold level.

Adjust the RXSS- threshold level as follows:

1. Turn the RXSS- threshold level potentiometer fully counter-clockwise (left-hand stop).
2. Deactivate the transmitter by jumpering pin 1 to pin 3 of connector J2.
3. Ensure that no other reading units are transmitting, by connecting pin 1 to pin 3 of connector J2 (jumper) of all other RFMs in the area.
4. Monitor the voltage at RXSS- output pin with a voltmeter or an oscilloscope.
5. Turn the RXSS- threshold level adjustment potentiometer on the RFM clockwise, until the RXSS- output is just statically inactive. "Statically" means no voltage spikes present on the RXSS- signal. 'Inactive' means that the receive signal strength is below the RXSS- threshold level and not triggering RXSS- (the RXSS- output voltage remains > 4 V).
6. Remove all jumpers connected to J2.

**Note:** Reducing the RXSS- threshold level sensitivity (turning the potentiometer clockwise), reduces the sensitivity of the built-in receive signal strength detector. This has the effect that the distance for wireless detection of other transmitting reading units is decreased, leading to reduction of wireless synchronization distance. The wireless synchronization distance between two reading units is normally about 15 meters for two aligned stick antennas (RI-ANT S02) with maximum receive field strength detection sensitivity.

When the RXSS- threshold level is adjusted such that it is too sensitive, then the RXSS- output is constantly active (i.e. low RXSS- output level). Therefore a Control Module assumes that another reading unit is transmitting and continually tries to synchronise to this other reading unit. As a result, the reading repetition rate decreases from approximately 10 down to 5 readings per second. This reading unit can additionally no longer synchronise to other reading units, causing interference with other reading units and reading at all reading units becomes impossible.

The RXSS- threshold level must be adjusted individually for every RFM and reading system antenna. In addition, the RXSS- threshold level must be individually adjusted to the local noise level in the application area where the antenna is used.

As high noise levels mean that the RXSS- threshold level must be adjusted to a less sensitive value, it is recommended to reduce the local noise level in order to have high synchronization sensitivity and a long reading distance.

The RXSS- threshold level must be adjusted so that no spikes occur on the RXSS- signal output since these lead to an incorrect synchronization function. An oscilloscope should therefore be used when adjusting the threshold level.

The Antenna Tuning Indicator (RI-ACC-AT12) accessory can be used to adjust the RXSS- threshold level, since this device automatically switches the transmitter off and has an internal spike extension circuit, causing the RXSS- threshold level to be adjusted such that no spikes occur on the RXSS- output.

---

## Transmitter Carrier Phase Synchronization (CPS)

In some applications it is necessary to use several charge-up antennas close to each other. Under these circumstances, the magnetic charge-up fields generated by different antennas superimpose on each other and may cause a beat effect on the magnetic charge-up field, due to the slightly different transmit frequencies of different RFMs.

The impact of this effect depends on three factors:

1. Antenna size:

The larger the size of the antennas, the further the distance between the antennas must be, so that this effect does not occur.

2. Magnetic field strength:

The stronger the generated magnetic field strength, the further the distance between the antennas must be such that the effect does not occur.

3. Orientation and distance between antennas:

Increasing the distance between antennas decreases the impact of this effect.

---

**Note:** Putting two antennas close together also changes antenna inductance, so that the antennas may no longer be tuneable to resonance.

---

If several antennas are used close to each other, a check should be made to determine if the charge-up field strength changes regularly (i.e. beat effect). This may be checked by verifying the antenna resonance voltage with an oscilloscope. If the antenna resonator voltage changes periodically by more than approximately 5% of the full amplitude it is appropriate to use wired transmitter carrier phase synchronization.

In addition, the distances given in [Table E-1](#) can be used as a guideline to determine when it is necessary to cross-check for beat effect. If these distances are less than the value given in [Table E-1](#), a check for beat effect should be made. The values given refer to the distances shown in [Figure E-1](#) and are valid for maximum charge-up field strength.



**Figure E-1. Distance Between Antennas (Top View)**

**Table E-1. Maximum Distances Between Antennas**

Antenna type	Distance D1 [m]	Distance D2 [m]
RI_ANT_S02 <=> RI_ANT_S02	0.8	1.0
RI_ANT_G01 <=> RI_ANT_G01	1.7	1.5
RI_ANT_G02 <=> RI_ANT_G02	1.3	1.0
RI_ANT_G04 <=> RI_ANT_G04	2.0	1.7

This effect will not occur if the transmitters of different RFMs are operated from the same oscillator signal. This is the reason why the pulse width modulated oscillator signal is accessible at the connector J1.

### Configuration

Master or Slave setting of a RFM is determined by switch 1 position 1 (SW1/1). If this is in the ON position, the RFM is a MASTER, if in the OFF position, it is a SLAVE. When a RFM has been configured as a master, then J1 pin 12 of this unit should be connected to J1 pin 16 of the slave units to allow the master oscillator output (CPS\_OUT) to drive the slave oscillator inputs (CPS\_IN). The logic ground (e.g. J1 pin 1) of both master and slave units should be connected together.

#### CAUTION

Use overvoltage protection components at the CPS connector for CPS lines between 0.5m and 5m.

---

**Note:** When using the transmitter Carrier Phase Synchronization feature, it is absolutely necessary that the read cycles of each of the different Control Modules are synchronized. When the transmitter of the oscillator MASTER RFM is not activated by its Control Module, the oscillator signal output of the oscillator MASTER RFM is disabled. This means that all the oscillator SLAVE RFMs have no transmitter oscillator input signal and thus none of the oscillator SLAVE RFMs are able to transmit.

---

The read cycles of all RFMs connected to this CPS interface must be synchronized and all read cycles must occur simultaneously. Refer to the Hardware and Software Manuals for the TI-RFid Control Modules for more information about the necessary wiring and settings for synchronization of the RFM when using transmitter Carrier Phase Synchronization (CPS). If an application requires more than one RFM to be used, or a longer Carrier Phase Synchronization line than that specified in [Chapter 2, Specifications](#), must be used, it is necessary to drive the pulse width modulated oscillator signal via a differential interface such as an RS422 interface.

## Noise Considerations

Noise can have a negative effect on the receive performance of the RFM. There are two different kinds of noise: radiated and conducted. Their characteristics are shown in [Table F-1](#).

**Table F-1. Characteristics of Radiated and Conducted Noise**

	<b>Radiated Noise</b>	<b>Conducted Noise</b>
Source	Inductive parts; for example, deflection coils, motor coils.	Power units, for example: motors, switched mode power supplies. Can be seen as voltage spikes or ripple voltage.
Path	Via magnetic fields.	Galvanically conducted via all cables (supply and interface) connected to the RFM.
Effect	Disturbs receive function by magnetic interference with signal from transponder at the antenna.	Leads to malfunction and reduced sensitivity of receiver circuitry due to, for example, interfered supply voltage. Conducted noise can also cause radiated noise.

### Method for detecting and distinguishing between noise types:

The principle of this procedure is to eliminate any conducted noise from the supply and all interface lines. In order to do this test the RFM must be powered from a battery (for example: 9 V, 20 mA) in order to eliminate any conducted noise from a power supply. Conducted noise via the interface lines is eliminated for this test by simply disconnecting all interface lines to the RFM. The measurement criteria for low noise is the amplitude of the receive signal strength detector of the RFM.

The test pin RSTP at connector J1 pin 10 carries an analog output voltage indicating the receive signal strength. This voltage should be measured in combination with the antenna RI-ANT-G02. The necessary set-up for this test is shown in [Figure F-1](#). This configuration operates the RFM from a battery and has no interface line connected. As the transmitter is switched off in this configuration, a normal battery may be used. A low noise level is indicated by an RSTP voltage of less than 1.0 VDC when using antenna RI-ANT-G02.

---

**Note:** Both noise types can be either differential or common mode noise. Use common mode noise filters (for example: a BALUN transformer) to reduce common mode noise and use selective filters to reduce differential noise.

---

The following procedure for testing for noise impact should be implemented when the normal set-up for the RFM and antenna gives bad reading distances, even though the antenna is correctly tuned for sufficient transponder charge-up.

Try the configuration shown in [Figure F-1](#). If this configuration shows bad noise conditions (RSTP voltage more than approximately 1.0 VDC) then the problem is radiated noise.

Eliminate noise sources or try special antennas (e.g. noise-balanced antennas).

1. When the configuration of [Figure F-1](#) shows good noise conditions (RSTP voltage less than 1.0 VDC) then the problem is conducted noise.
2. Change the configuration so that the interface lines are again connected to the RFM with the transmitter still switched off. If the RSTP voltage now indicates bad noise conditions, the conducted noise is coming via the interface lines.
3. Try to eliminate the noise on the interface lines. See [Appendix G](#), Over Voltage Protection.
4. When the configuration above (interface lines connected) shows good noise conditions (RSTP voltage less than 1.0 VDC), then the problem is conducted noise via the supply lines.
5. Try to eliminate the noise on the supply lines. See [Appendix G](#), Over Voltage Protection.

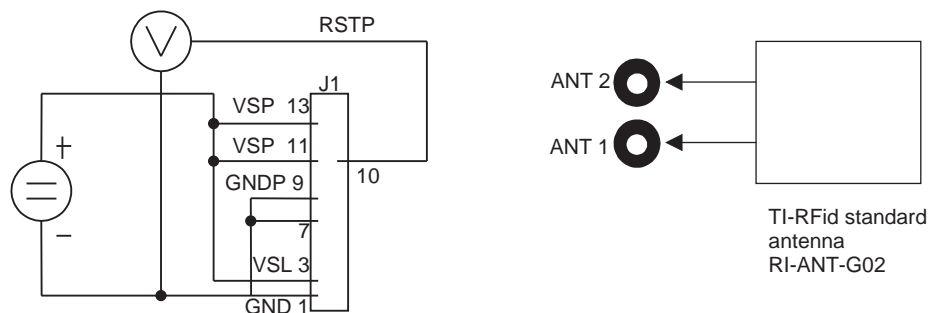

**Figure F-1. Noise Testing Configuration**

## Over Voltage Protection

---

---

---

For applications where there is a risk that voltage spikes and noise are on the lines to the RFM, additional protection circuitry and filters must be added. A proposal on how this may be achieved is shown in [Figure G-1](#), and this circuit may be used as a guideline for protection circuitry. This may not be sufficient for all applications, however, and must be checked individually when necessary.

1. The supply input has to be protected against voltage spikes. R1 and D1 fulfil this purpose. Zener diode D1 clamps the voltage spikes to 18 volts so that the maximum allowed transmitter power stage supply voltage is not appreciably exceeded. For diode D1, type ZY18 is recommended, this type having a 2 W power dissipation. If a higher current is needed, dump type ZX18 may be used, this diode having a 12.5 W power dissipation.
2. The Common Mode Choke Coil and the capacitors C1 and C2 are used to reduce the conducted noise coming to the RFM via the supply lines.
3. All input and output signals should be protected with 5.6 V zener diodes. The specified type can dump 1.3 W.
4. The coils L1 to L6 are ferrite beads and should put in series to the line when conducted noise is observed entering via the interface lines.
5. The varistor V1 protects the antenna circuit against high voltage induced at the antenna coil, for example by lightning. The type of varistor given is commonly available but may not be sufficient for protection in all cases.

---

**Note:** The zener diodes types given in [Figure G-1](#) are commonly used types, not special suppresser diodes for fast voltage spike suppression. If the application requires it, special suppresser diodes should be used.

---

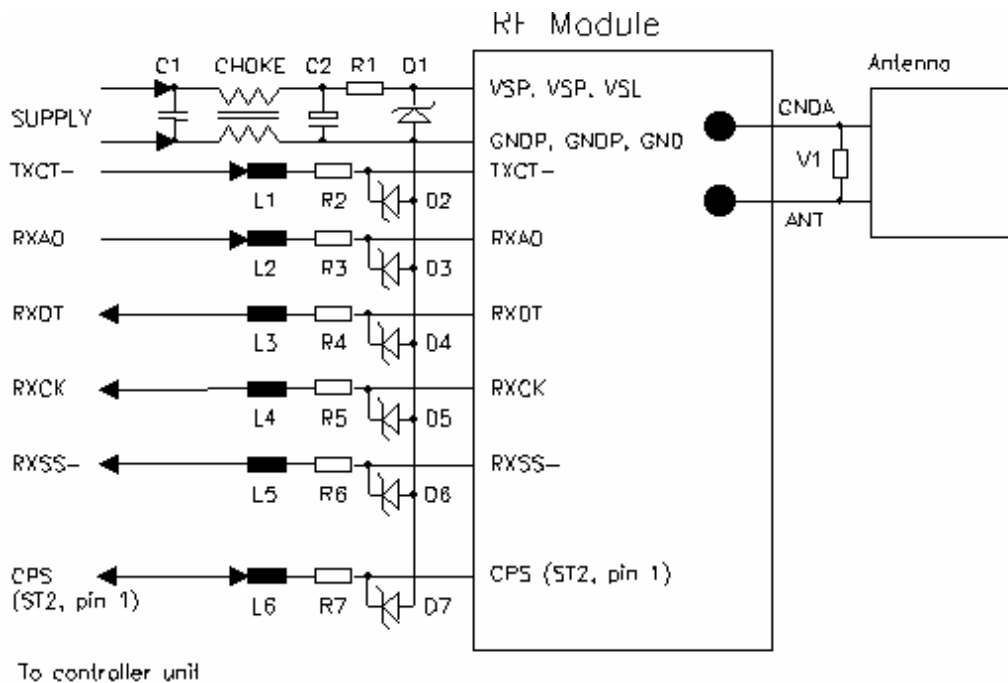

**Figure G-1. Circuit for Overvoltage Protection**

All components must be mounted close to the RFM with the shortest possible wiring		
C1: 100 nF Ceramic	R1: 1 $\Omega$ / 2 W	V1: Varistor 420V e.g Siemens S10V-520K420
C2: 100 $\mu$ F low ESR	R2, R3, R4, R5, R6, R7: 22 $\Omega$ / 0.25 W	
CHOKE: Common Mode Choke Coil L1, L2, L3, L4, L5, L6: Ferrite beads	D1: ZY18 resp. ZX18 D2, D3, D4, D5, D6, D7: BZX85C5V6	



## IMPORTANT NOTICE

Texas Instruments Incorporated and its subsidiaries (TI) reserve the right to make corrections, modifications, enhancements, improvements, and other changes to its products and services at any time and to discontinue any product or service without notice. Customers should obtain the latest relevant information before placing orders and should verify that such information is current and complete. All products are sold subject to TI's terms and conditions of sale supplied at the time of order acknowledgment.

TI warrants performance of its hardware products to the specifications applicable at the time of sale in accordance with TI's standard warranty. Testing and other quality control techniques are used to the extent TI deems necessary to support this warranty. Except where mandated by government requirements, testing of all parameters of each product is not necessarily performed.

TI assumes no liability for applications assistance or customer product design. Customers are responsible for their products and applications using TI components. To minimize the risks associated with customer products and applications, customers should provide adequate design and operating safeguards.

TI does not warrant or represent that any license, either express or implied, is granted under any TI patent right, copyright, mask work right, or other TI intellectual property right relating to any combination, machine, or process in which TI products or services are used. Information published by TI regarding third-party products or services does not constitute a license from TI to use such products or services or a warranty or endorsement thereof. Use of such information may require a license from a third party under the patents or other intellectual property of the third party, or a license from TI under the patents or other intellectual property of TI.

Reproduction of information in TI data books or data sheets is permissible only if reproduction is without alteration and is accompanied by all associated warranties, conditions, limitations, and notices. Reproduction of this information with alteration is an unfair and deceptive business practice. TI is not responsible or liable for such altered documentation.

Resale of TI products or services with statements different from or beyond the parameters stated by TI for that product or service voids all express and any implied warranties for the associated TI product or service and is an unfair and deceptive business practice. TI is not responsible or liable for any such statements.

Following are URLs where you can obtain information on other Texas Instruments products and application solutions:

<b>Products</b>		<b>Applications</b>	
Amplifiers	<a href="http://amplifier.ti.com">amplifier.ti.com</a>	Audio	<a href="http://www.ti.com/audio">www.ti.com/audio</a>
Data Converters	<a href="http://dataconverter.ti.com">dataconverter.ti.com</a>	Automotive	<a href="http://www.ti.com/automotive">www.ti.com/automotive</a>
DSP	<a href="http://dsp.ti.com">dsp.ti.com</a>	Broadband	<a href="http://www.ti.com/broadband">www.ti.com/broadband</a>
Interface	<a href="http://interface.ti.com">interface.ti.com</a>	Digital Control	<a href="http://www.ti.com/digitalcontrol">www.ti.com/digitalcontrol</a>
Logic	<a href="http://logic.ti.com">logic.ti.com</a>	Military	<a href="http://www.ti.com/military">www.ti.com/military</a>
Power Mgmt	<a href="http://power.ti.com">power.ti.com</a>	Optical Networking	<a href="http://www.ti.com/opticalnetwork">www.ti.com/opticalnetwork</a>
Microcontrollers	<a href="http://microcontroller.ti.com">microcontroller.ti.com</a>	Security	<a href="http://www.ti.com/security">www.ti.com/security</a>
Low Power Wireless	<a href="http://www.ti.com/lpw">www.ti.com/lpw</a>	Telephony	<a href="http://www.ti.com/telephony">www.ti.com/telephony</a>
		Video & Imaging	<a href="http://www.ti.com/video">www.ti.com/video</a>
		Wireless	<a href="http://www.ti.com/wireless">www.ti.com/wireless</a>

Mailing Address: Texas Instruments  
Post Office Box 655303 Dallas, Texas 75265